

IR-Cut 模组

普通模组

REVISION RECORD			
LTR	ECO NO.	APPROVED:	DATE:



图 1-1 MIPI 接口 (2 lane) 外围电路



图 2-2 MIPI 接口 (2 lane) 外围电路

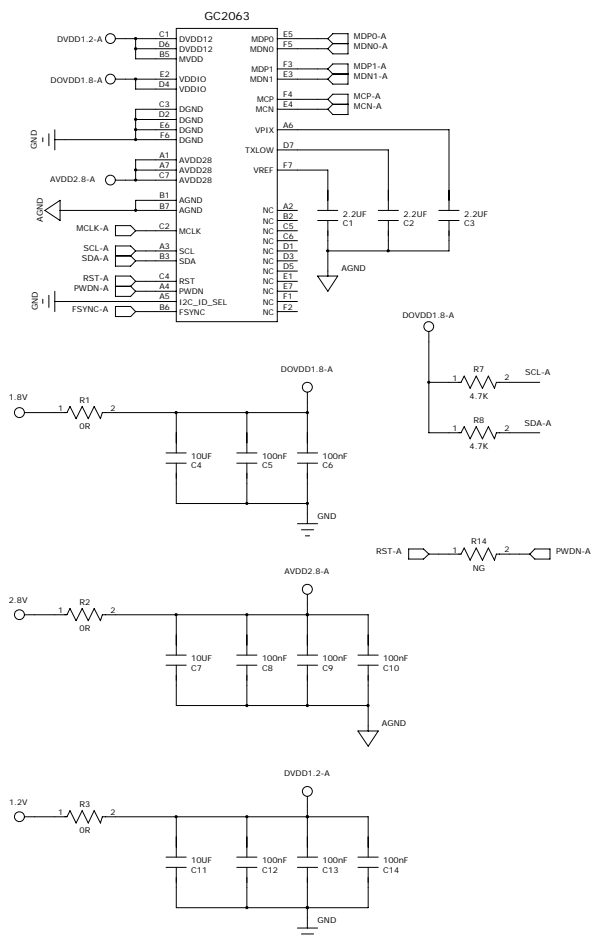

FH19SC-40S-0.5SH

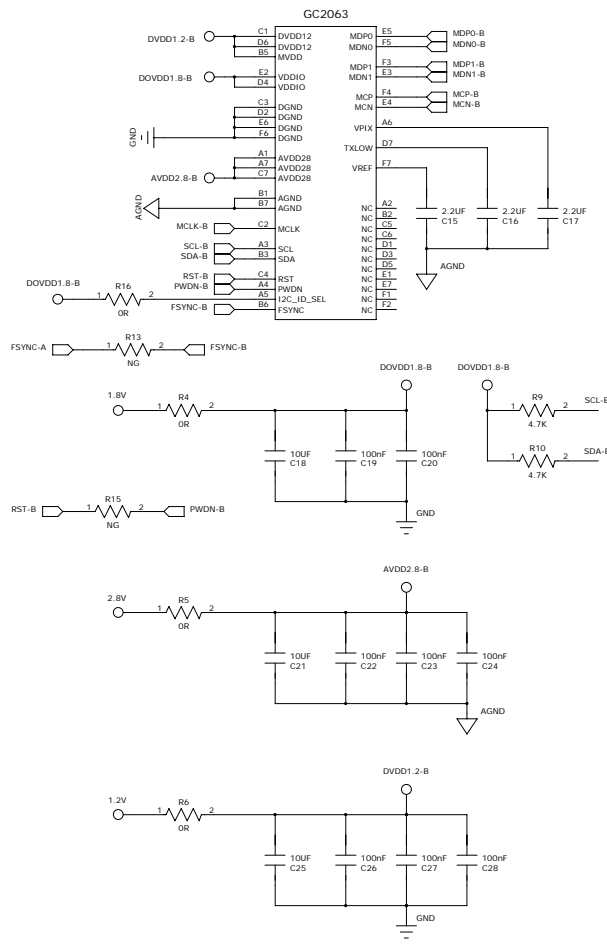
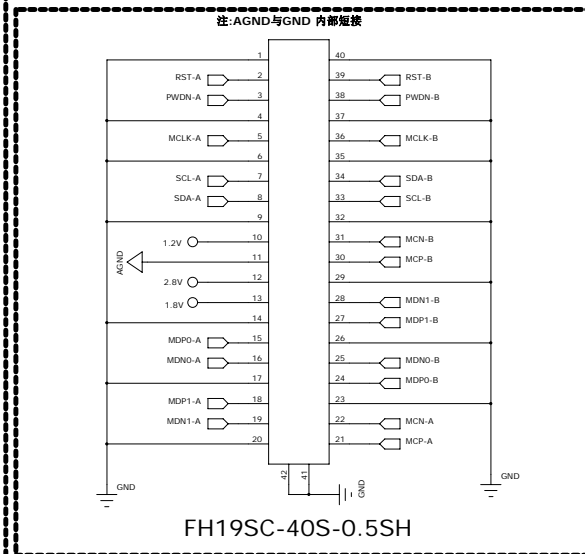
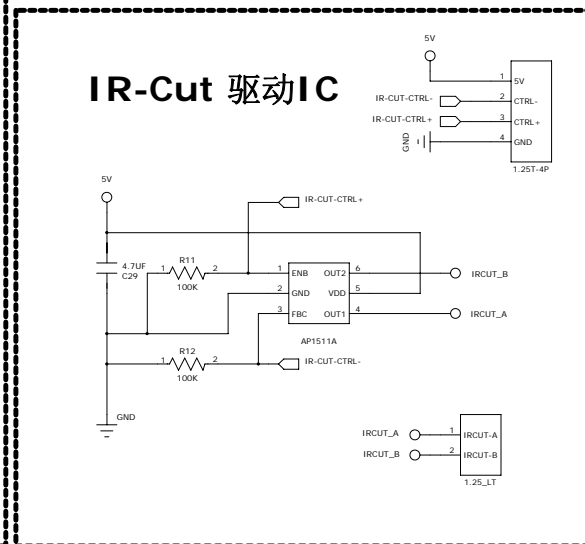

IR-Cut 驱动IC

芯片: GC2063-C41Y0 (1/2.9 inch,1920*1080)
 NOTE: 1. AVDD2.8V
 2. DVDD1.2V
 3. DOVDD1.8V
 4. RESET 高工作
 5. PWDN:高工作
 6. IR-Cut 模组:OX6e

芯片: GC2063-C41Y0 (1/2.9 inch,1920*1080)
 NOTE: 1. AVDD2.8V
 2. DVDD1.2V
 3. DOVDD1.8V
 4. RESET 高工作
 5. PWDN:高工作
 6. 普通模组:OX7E

DRAWN:	周工	DATED:	
CHECKED:		DATED:	
QUALITY CONTROL:		DATED:	
RELEASED:		DATED:	

COMPANY: 信丰世嘉科技有限公司			
TITLE: IOT362G6363-A			
CODE:	SIZE:	DRAWING NO:	REV:
SCALE:			SHEET: 1 of 1